



series MX-3

CHEMICAL INJECTION PUMPS



PRODUCT FEATURES OF THE MX-3

- Up to 62 gallons (235 liters) per day
- Lightweight
- Discharge pressures to 10,000 PSI (690 Bars)
- Adjustable flow rate
- Positive cycle operation
- Easily field serviceable
- 316 SS fluid end
- Capable of handling dirty/sour gas
- 1 to 60 Strokes Per Minute
- Low gas consumption
- Inlet pressure: 145 PSI (10 bars) maximum
30 PSI (2.1 bars) minimum
- Adjustable vee packing

MODEL NUMBER

Plunger Diameter	Pump Model Number	Weight
3/16	MX34-1	12.5#
1/4	MX31-1	14#
3/8	MX33-1	14#
1/2	MX35-1	15#



PARTS LIST

Item	Part No.	No. Reqd.	Name	Material
1	TC-2124	1	Power Unit	
2	TA-6320	1	Nipple	SST
3	TA-5851	1	Speed Control Valve	Aluminum
4	TB-1595	1	Yoke Cover (not shown)	Plastic
5	P04-031250-3900	4	Bolts- 5/16 - 24UNF x 2-1/2	SST
6	TC-2114	1	Yoke Housing	Aluminum
7	TA-5953	1	Drive Clip	SST
8	TC-2121*	1	Fluid End Assembly	

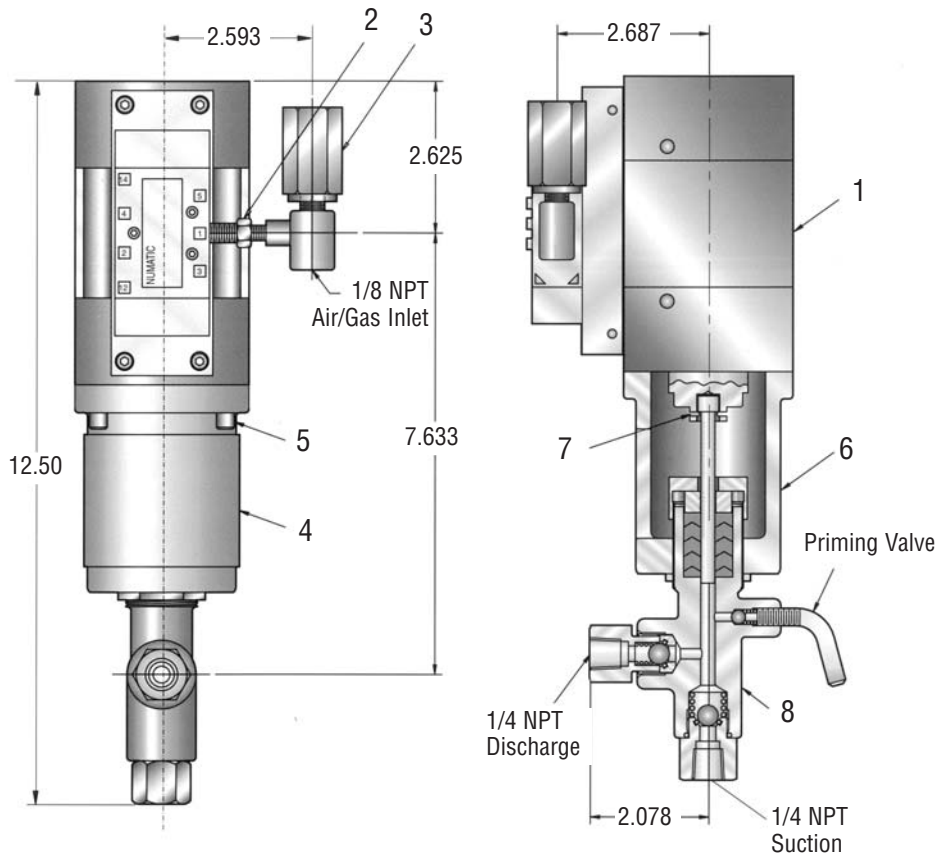

Double Headed MX-Pump

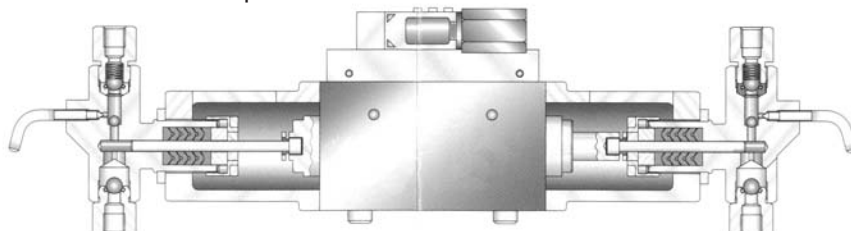

ACCESSORIES



Mounting Bracket

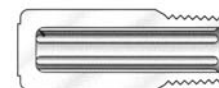

Muffer, 1/4" NPT



Lubricator



Filter

INSTALLATION AND OPERATION

1. Remove the pump from the shipping container and inspect for visual damage.
2. Connect the chemical supply line to the pump suction port. The pump suction port connection is 1/4" FNPT.

Note: Simplex pumps should be mounted in vertical position with the suction port facing down, (brackets are available to assist in mounting). Duplex pumps should be mounted in horizontal position with suction ports facing down (mounting feet are available).

3. Connect tubing or piping to the discharge port to the pump. The discharge port connection is 1/4" FNPT and perpendicular to pump plunger axis.

Note: TXT recommends the installation of a line check at the point of injection into the line.

4. Loosen the locknut on the fluid end/yoke connection and rotate the power unit to align the control valve in a suitable location for installation requirements (care should be taken not to rotate the power more than 180 degrees). Retighten locknut upon completion.
5. Install a shut-off valve in the air/gas supply line.
6. Connect a 1/4" line from the air/gas shut-off to control valve.
7. The pump supply air/gas pressure must be a minimum of 30 PSI but no greater than 145 PSI. If the available supply pressure is greater than 145 PSI a regulator

must be installed to reduce the pressure to an acceptable level.

Note: For the best trouble free performance, a filter and lubricator should be installed in the air/gas supply line.

8. Open the supply line shut-off valve to the pump. The stroke rate is controlled by adjusting the calibrated control valve.
9. Exhaust air/gas should exit the power unit through the exhaust ports located on both sides of the control valve connection into the power unit.
10. Open the priming valve on the side of the fluid housing, (approximately 1/2 turn to allow trapped air to escape from the head). Continue to cycle the pump with the priming valve open until air bubbles are no longer visible in the fluid stream coming from the bleed hole.

Note: The media from the bleed hole can be piped to a container for safety purposes.

11. Control the output volume of the pump by adjusting the calibrated control valve. The pump can be operated at a stroke rate between 1 SPM minimum to a maximum of 60 SPM.
12. Once desired volume is established, the number on the barrel of a calibrated control valve should be noted, for returning to the same stroke rate and pump volume in the future.

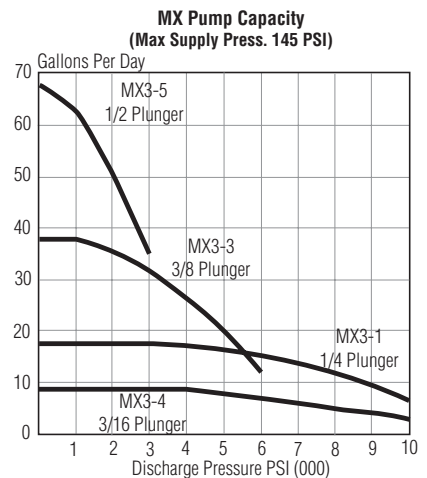
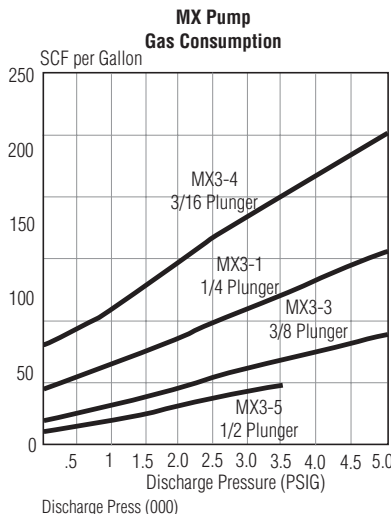
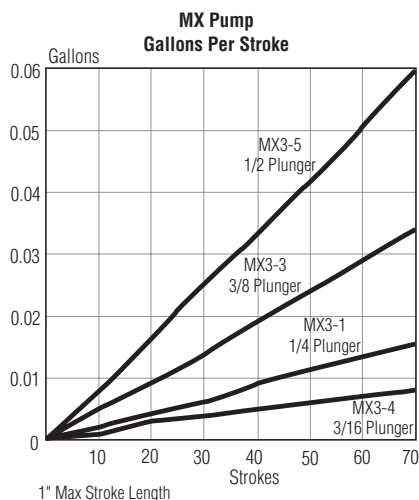

FLUID END PARTS LIST

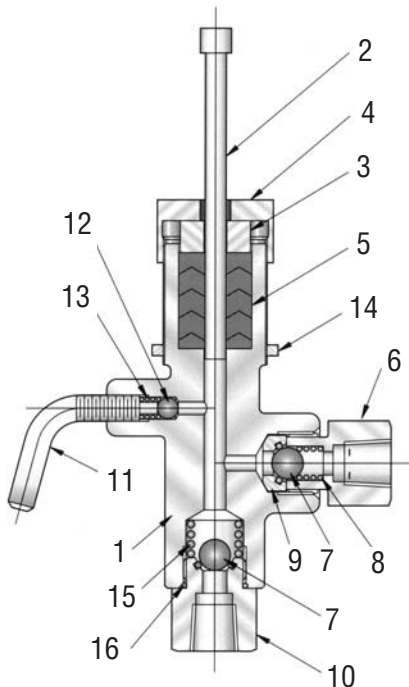

Item	Description	Material	Qty	3/16"	1/4"	3/8"	1/2"
	Fluid End Assy			TC2120	TC2121	TC2122	TC2123
1	Body	316 SS	1	TC2115	TC2116	TC2117	TC2118
2	Plunger	17-4PH	1	TA6268	TA6269	TA6270	TA6271
3	Packing Gland	303 SS	1	TA5642	TA1463	TA0957	TA1219
4	Packing Unit	303 SS	1	TA4104	TA4104	TA4104	TA4104
5	Packing	Buna		TA3969	TA1461	TA1456	TA0959
		Viton		TA3967	TA4102	TA4101	TA4103
		Teflon		TA3966	TA1642	TA1234	TA1012
		HP-Buna		TA3948	TA2295	TA1875	TA1874
		HP-Viton		TA6253	TA6263	TA6264	TA6265
6	Top Bushing	SS	1	TA1496	TA1496	TA1496	TA1496
7	Large Ball 3/8"	316 SS	1	TA0054	TA0054	TA0054	TA0054
8	Ball Ck Spring	316 SS	1	TA0077	TA0077	TA0077	TA0077
9	Seat	Buna		TB0737	TB0737	TB0737	TB0737
		Viton		TB0843	TB0843	TB0843	TB0843
		Teflon			TB1586	TB1586	TB1586
10	Bottom Bushing	Buna		TB0736	TB0736	TB0736	TB0736
		Viton		TB0844	TB0844	TB0844	TB0844
		Teflon			TB1587	TB1587	TB1587
11	Priming Valve	303 SS	1	TA6272	TA6272	TA6272	TA6272
12	Small Ball 1/4"	316 SS	1	TA0126	TA0126	TA0126	TA0126
13	P/V Spring	SS	1	TA6274	TA6274	TA6274	TA6274
14	Lock nut	Brass	1	TA0225	TA0225	TA0225	TA0225
15	Spring Ball Cage	SS	1	TA5378	TA5378	TA5378	TA5378
16	O-Ring		1				
Repair Kit		Buna		TA6311-B	TA6312-B	TA6313-B	TA6314-B
Fluid End Assembly		Viton		TA6311-V	TA6312-V	TA6313-V	TA6314-V
		Teflon			TB6312-T	TB6313-T	TB6314-T

PRESSURE / VOLUME

Model Number	Max Discharge		Volume			
	PSI	BARS	Maximum		Minimum	
			GPD	LPD	GPD	LPD
MX34-1 (3/16")	10,000	690	8.0	30.3	.11	.42
MX31-1 (1/4")	10,000	690	14.5	54.9	.2	.75
MX33-1 (3/8")	5,000	414	32.1	121.5	.6	2.27
MX35-1 (1/2")	3,500	241	62.0	234.7	1.1	4.16

Pressure Conversion Factors			
KG/SqCM	x	14.2	= PSIG
In./Hg	x	0.49	= PSIG
In. Water	x	0.036	= PSIG
Ft. of Water	x	0.43	= PSIG
Atmospheres	x	14.7	= PSIG
kPa	x	0.1450	= PSIG
Mega PA	x	145.0	= PSIG

Volume Conversion Factors			
cc/sec	x	0.95	= GPH
cc/min	x	0.016	= GPH
cc/hr	x	0.00026	= GPH
liters/sec	x	952.0	= GPH
liters/min	x	15.9	= GPH
liters/hr	x	0.264	= GPH
imperial GPM	x	72.0	= GPH
imperial GPH	x	1.20	= GPH
mi/sec	x	0.95	= GPH
mi/min	x	0.016	= GPH
mi/hr	x	0.00026	= GPH
m3/hr	x	264.2	= GPH



Dresser Industrial Products Group

16240 Port Northwest Drive
Houston, Texas 77041-2645

Phone: 832.590.2306
texsteam@dresser.com

Dresser, Inc.

Fax: 713.849.2879
www.dresser.com